

NOTES

1. PAINT STANDARD WHITE

REVISIONS			
REV.	DESCRIPTION	DATE	DRAWN BY
A	INITIAL RELEASE		

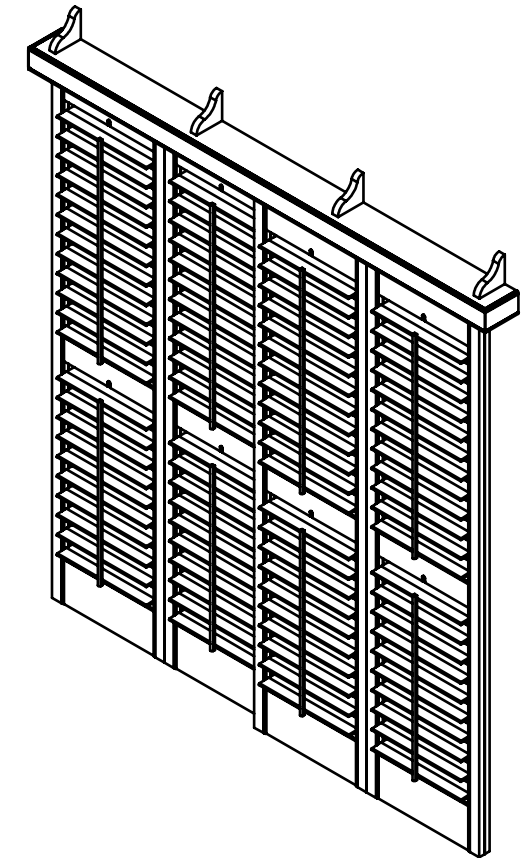
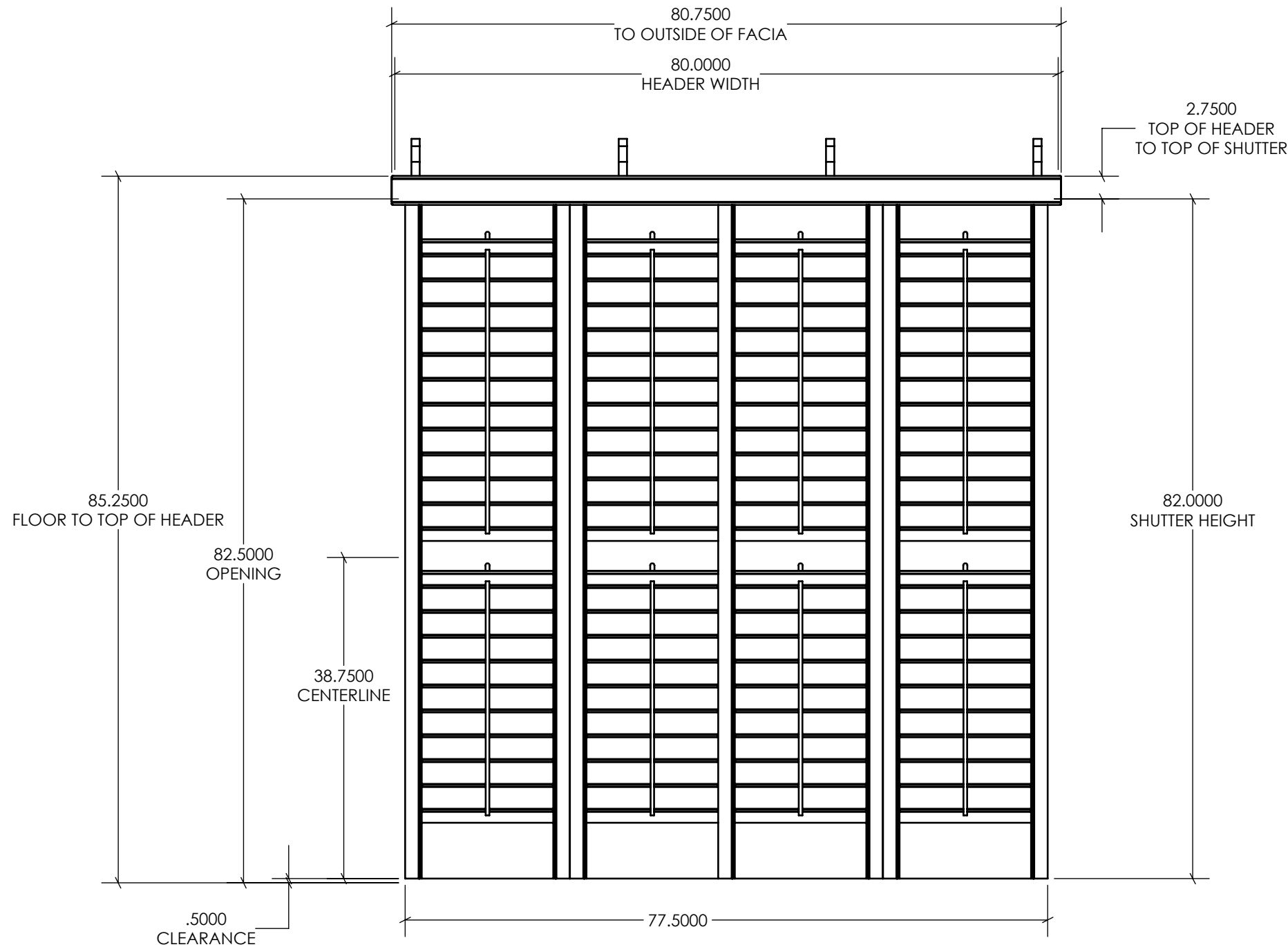

Approval Signature

Date

The signature (or AAN Stamp) on this print indicates the approval of the design, dimensions, and quantities shown. Authorization for this product to be manufactured is given.

*****ALL PARTS SHOWN ARE ADAMS STANDARD PROFILES*****

*****TWO DIMENSION REVISIONS ARE INCLUDED*****

*****ANY CHANGES TO PROFILES/PARTS WILL INCUR ADDITIONAL CHARGES*****

UNLESS OTHERWISE SPECIFIED DIMENSIONS ARE IN INCHES		2225 Kerper Blvd. Dubuque, IA 52001 563-690-1358 p 563-557-8852 f	
		Caribbean Rolling Shutter 4 Panel_Past Opening	
TOLERANCES:			
SHEET 1 OF 4	SIZE B		REV A

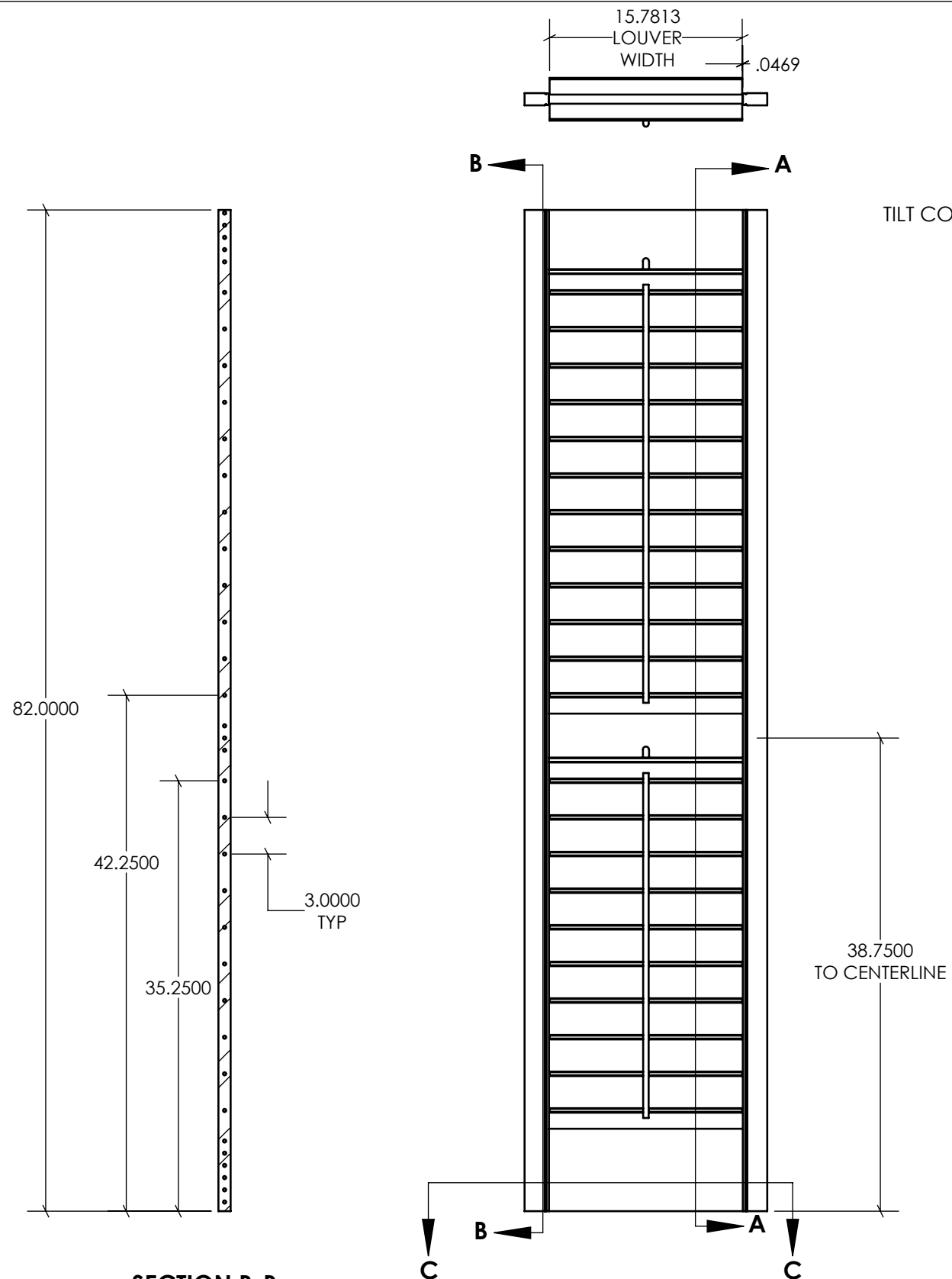

**SECTION B-B
(LOUVER HOLE LOCATIONS)**

SECTION A-A

SECTION C-C

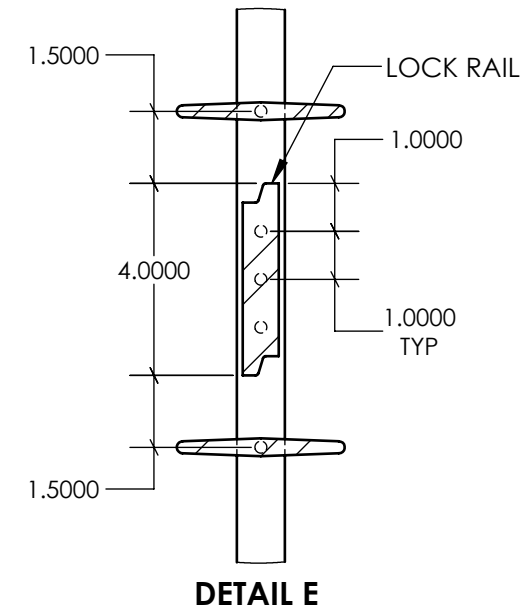
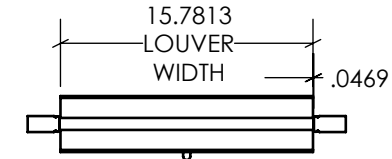
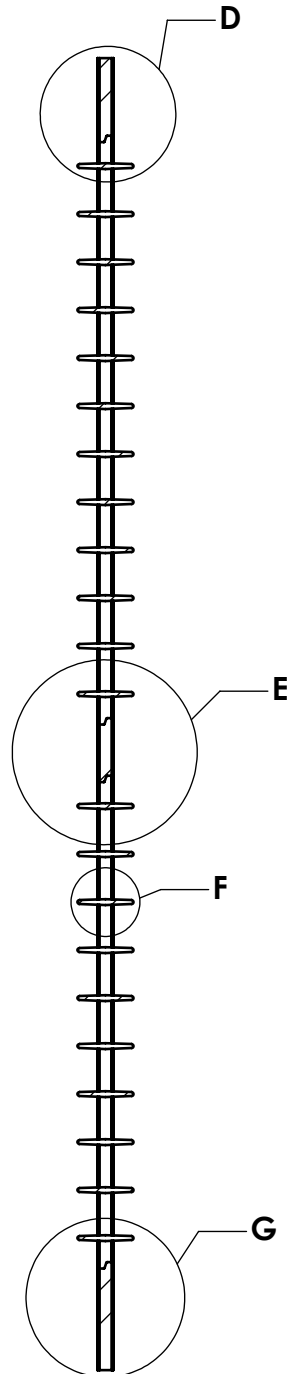
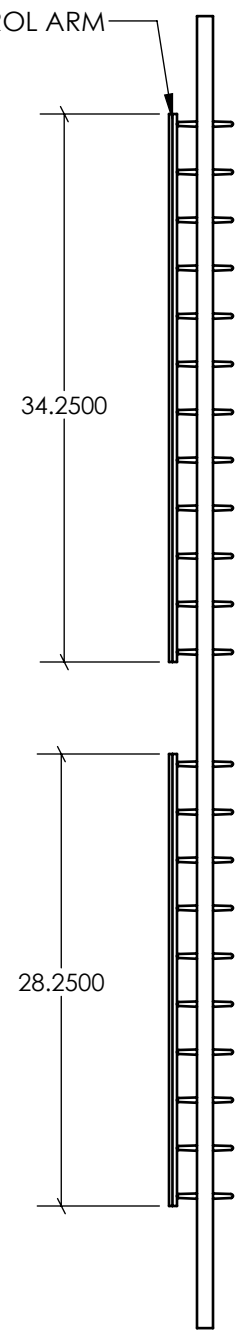
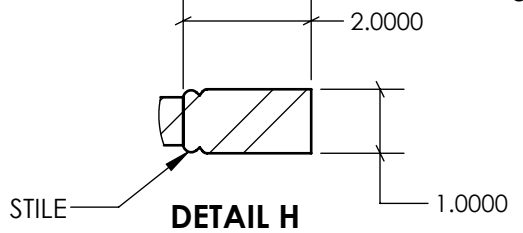
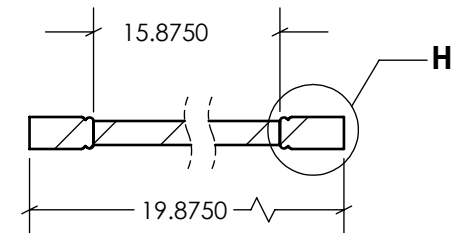

DETAIL E

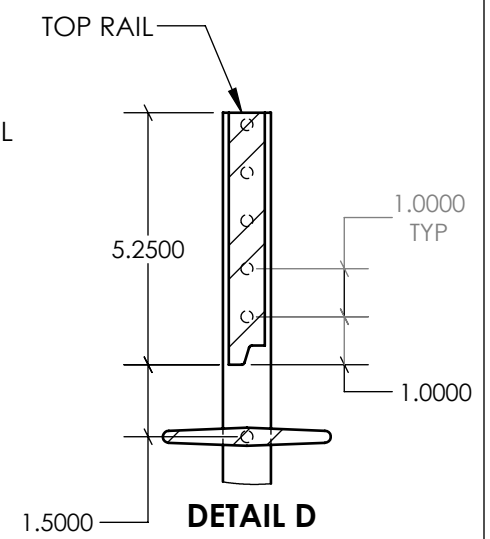

DETAIL D

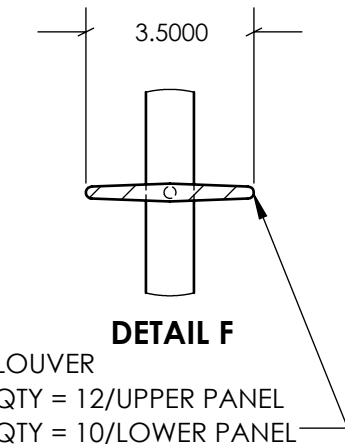

DETAIL F

LOUVER
QTY = 12/UPPER PANEL
QTY = 10/LOWER PANEL

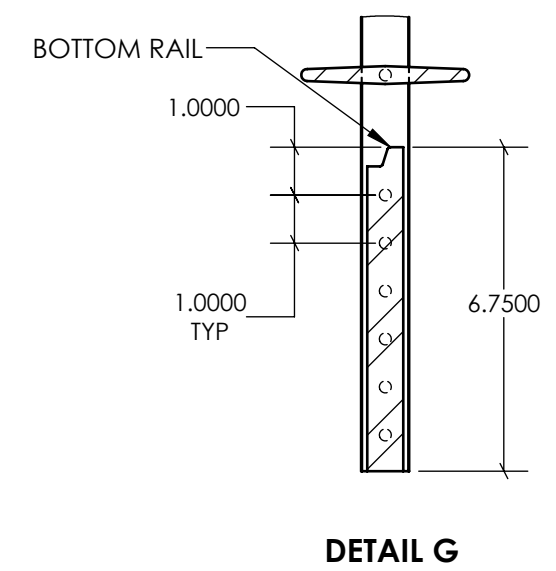

DETAIL G

UNLESS OTHERWISE SPECIFIED DIMENSIONS ARE IN INCHES TOLERANCES:			2225 Kerper Blvd. Dubuque, IA 52001 563-690-1358 p 563-557-8852 f
	Caribbean Rolling Shutter 4 Panel_Past Opening		
SHEET 2 OF 4	SIZE B	REV A	

SHUTTER STOPS

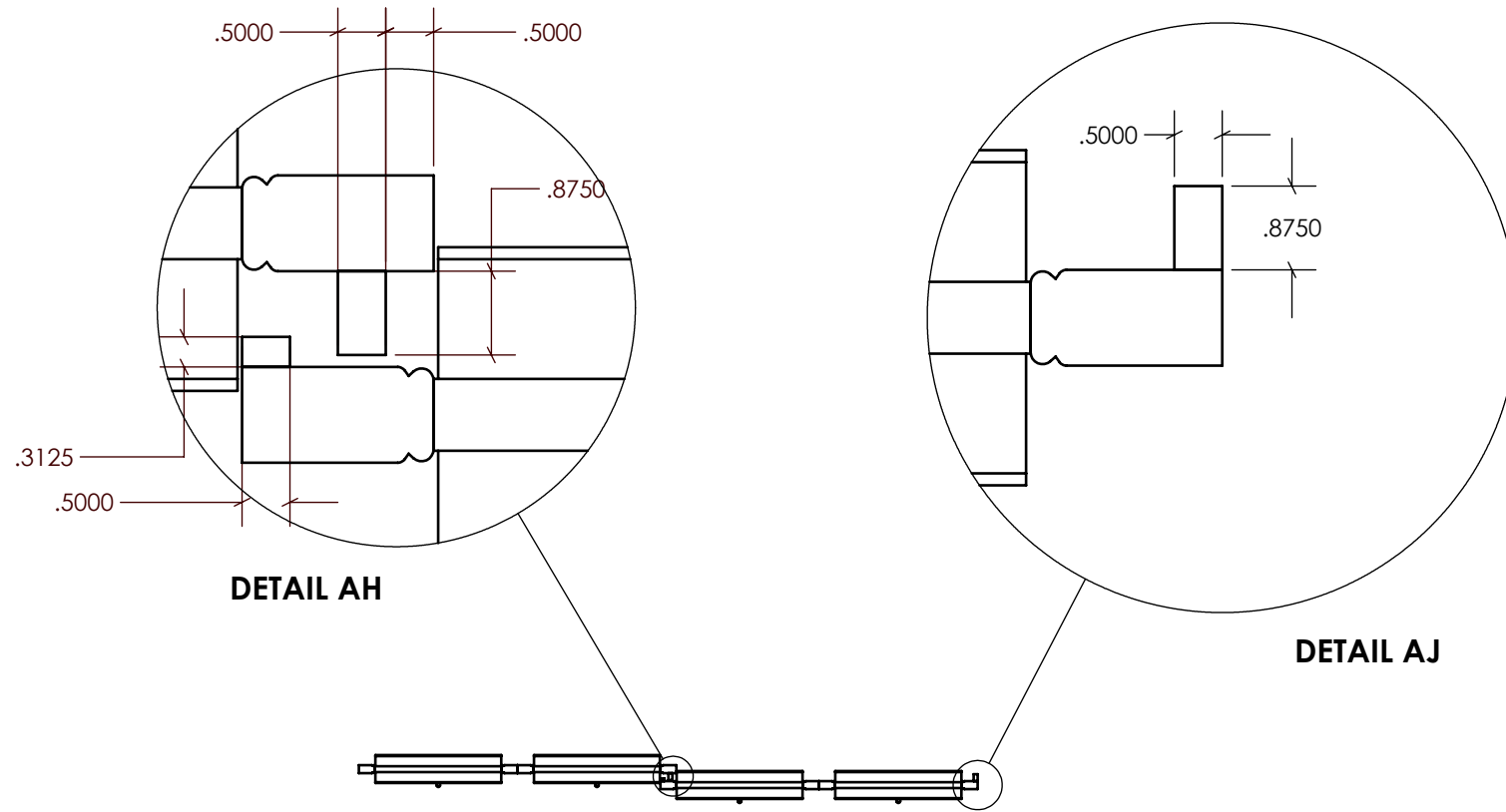

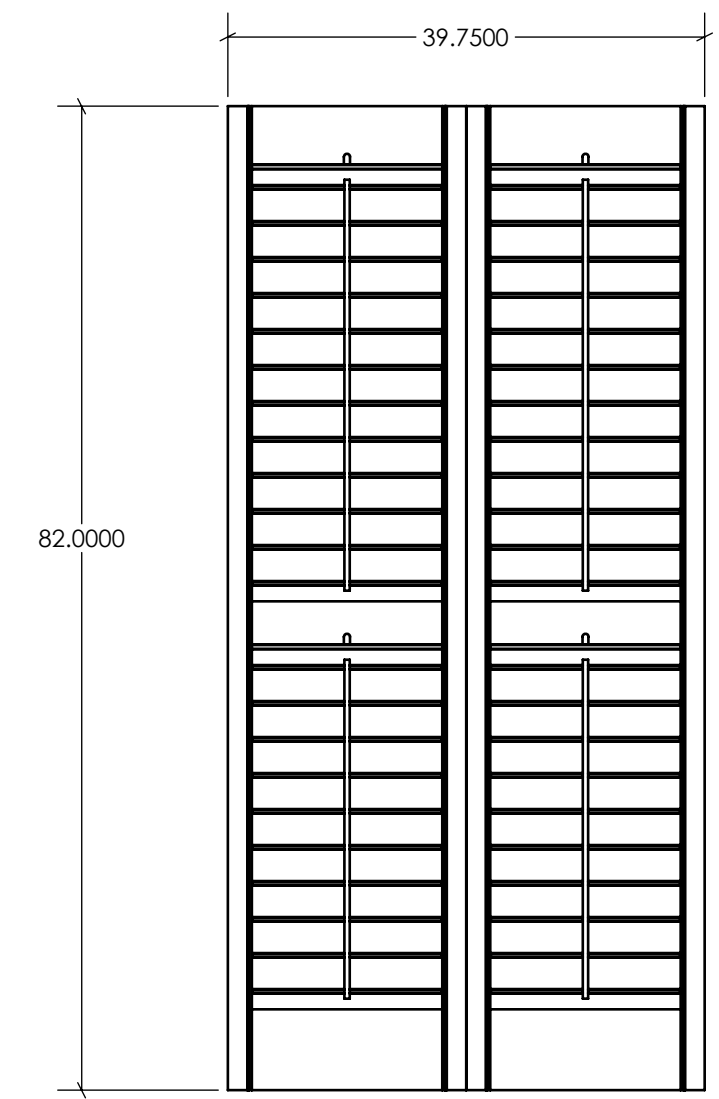
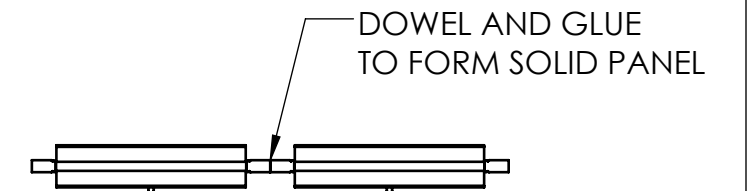
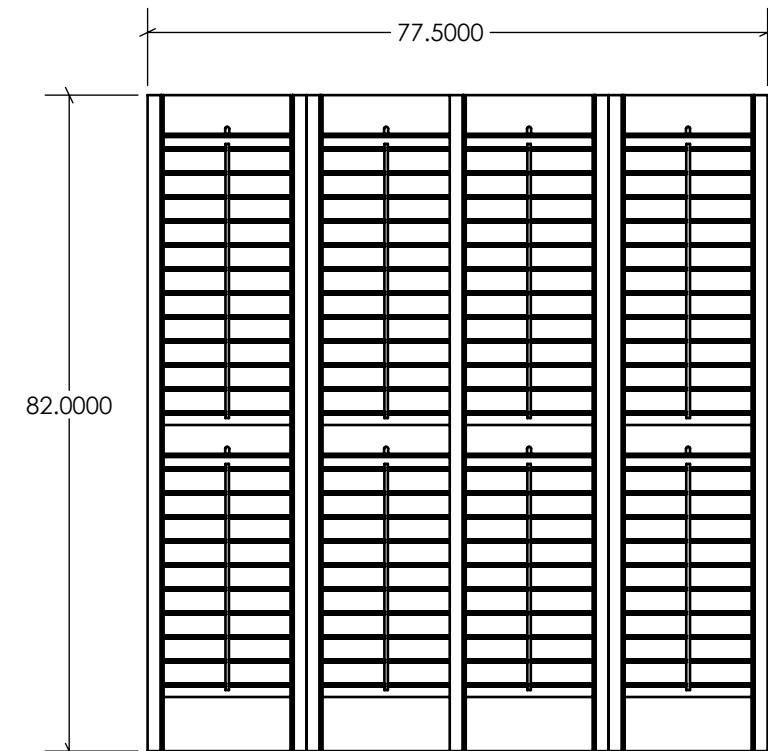

DETAIL AH

DETAIL AJ

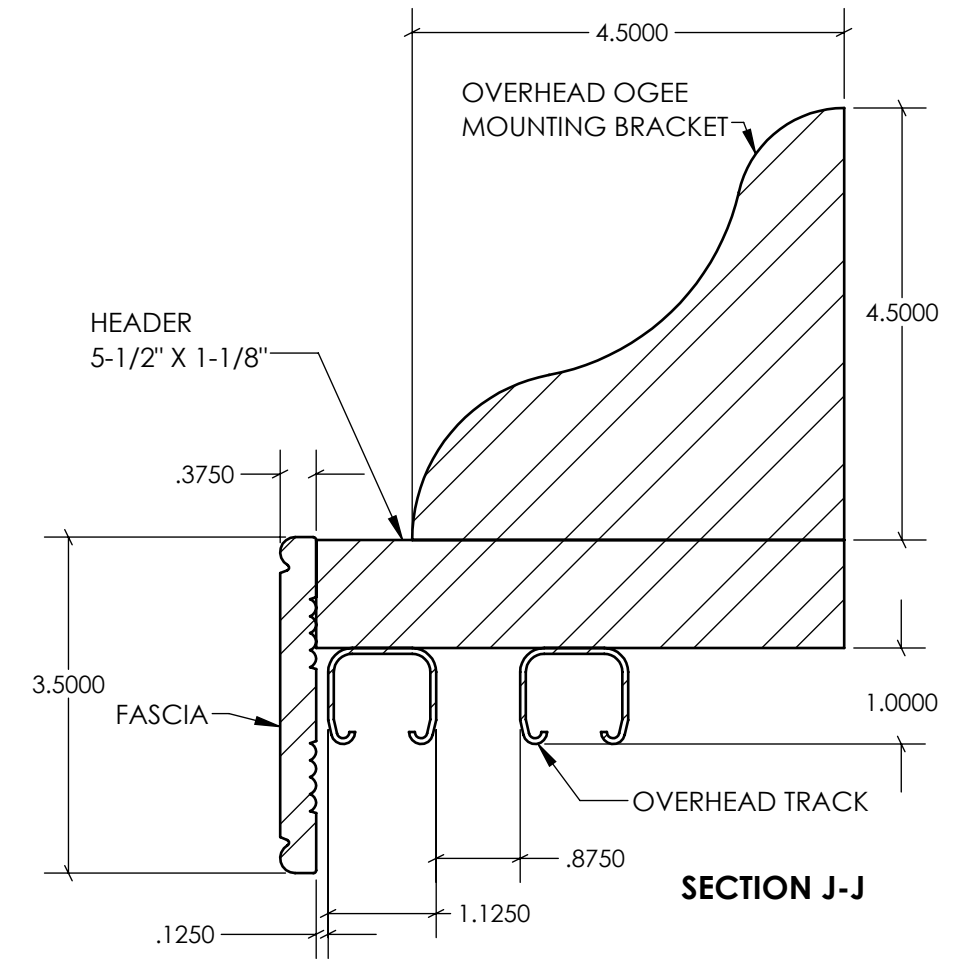
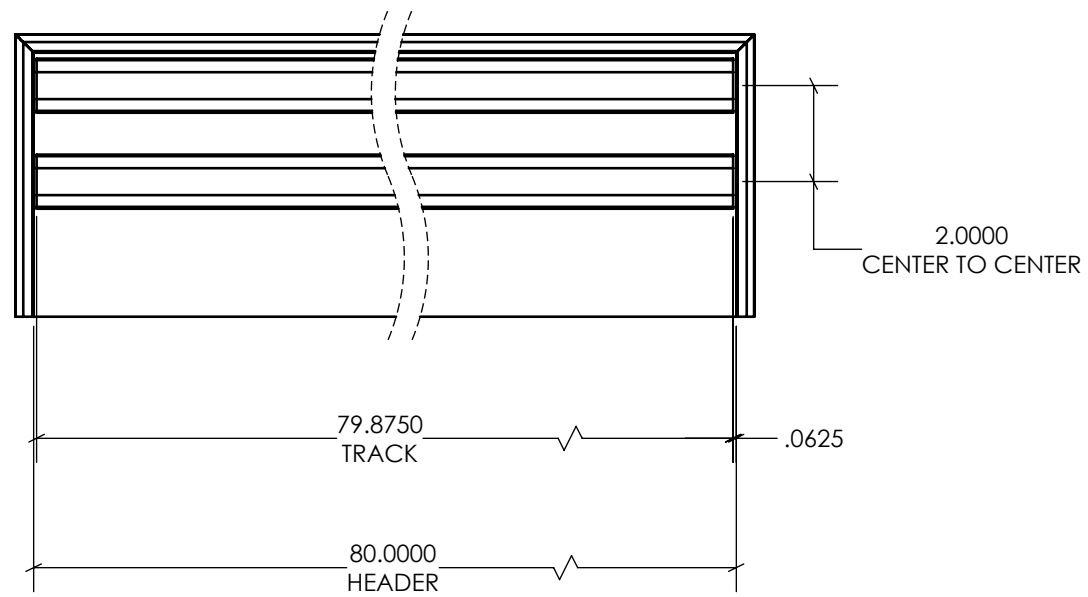
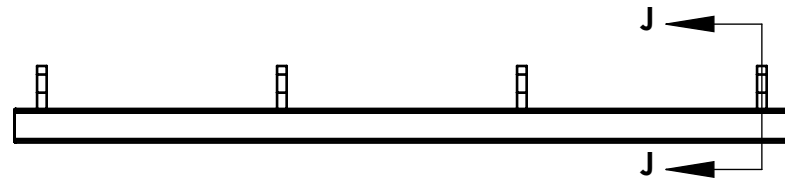

UNLESS OTHERWISE SPECIFIED DIMENSIONS ARE IN INCHES TOLERANCES:		2225 Kerper Blvd. Dubuque, IA 52001 563-690-1358 p 563-557-8852 f	
		Caribbean Rolling Shutter 4 Panel_Past Opening	
SHEET 3 OF 4	SIZE B		REV A



UNLESS OTHERWISE SPECIFIED DIMENSIONS ARE IN INCHES		2225 Kerper Blvd. Dubuque, IA 52001 563-690-1358 p 563-557-8852 f	
		Caribbean Rolling Shutter 4 Panel_Past Opening	
TOLERANCES:			
SHEET 4 OF 4	SIZE B		REV A