

**NOTES**

1. PAINT BENJAMIN MOORE OC-117 SIMPLY WHITE

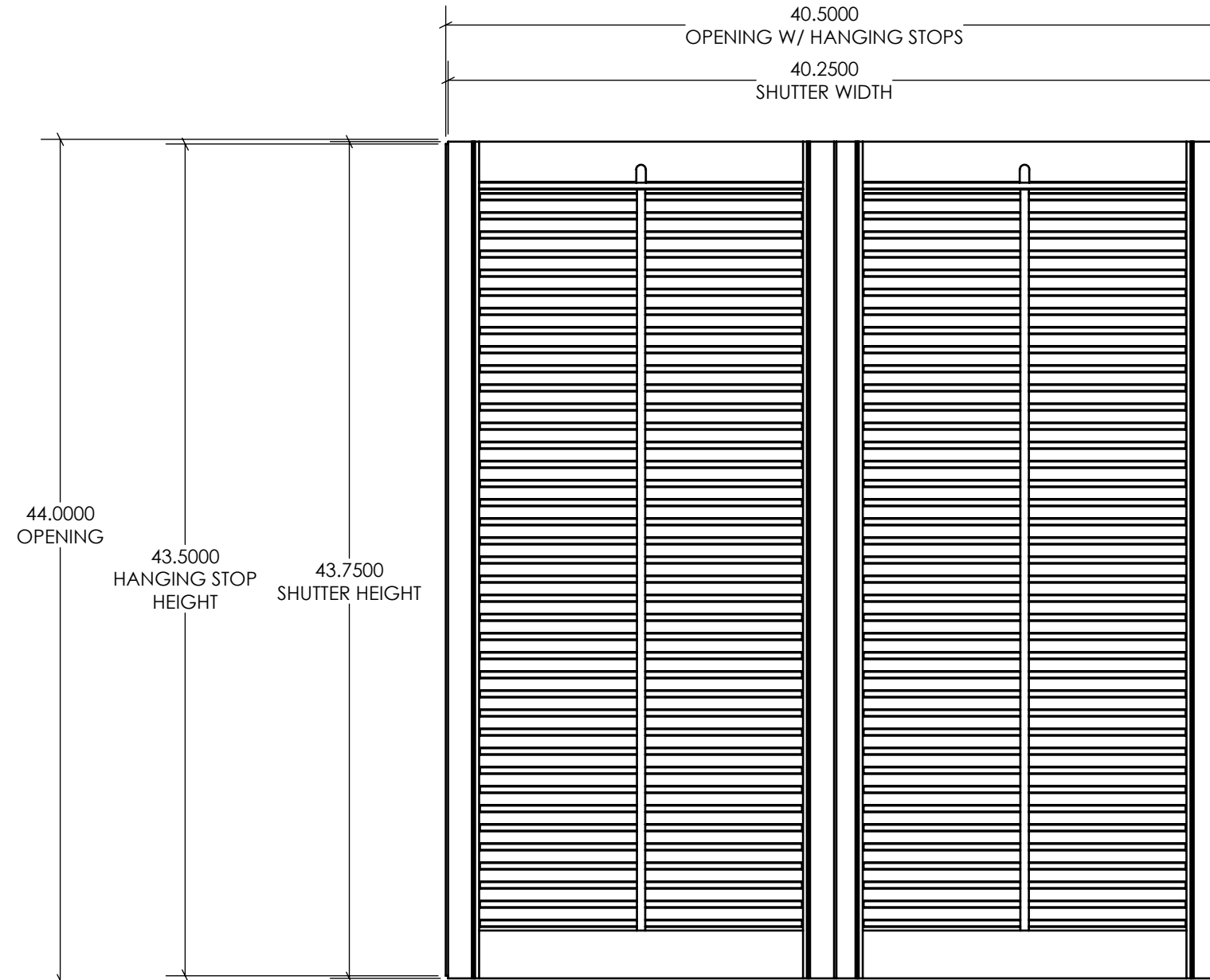
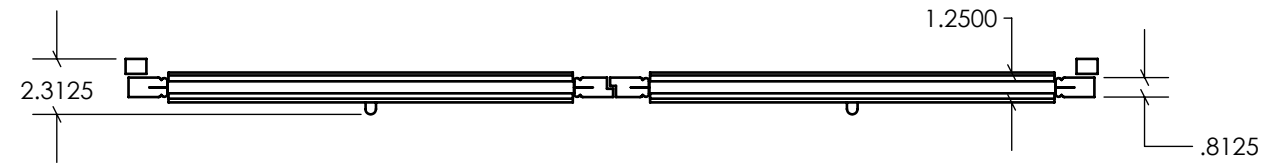

REVISIONS

REV.	DESCRIPTION	DATE	DRAWN BY
A	INITIAL RELEASE		

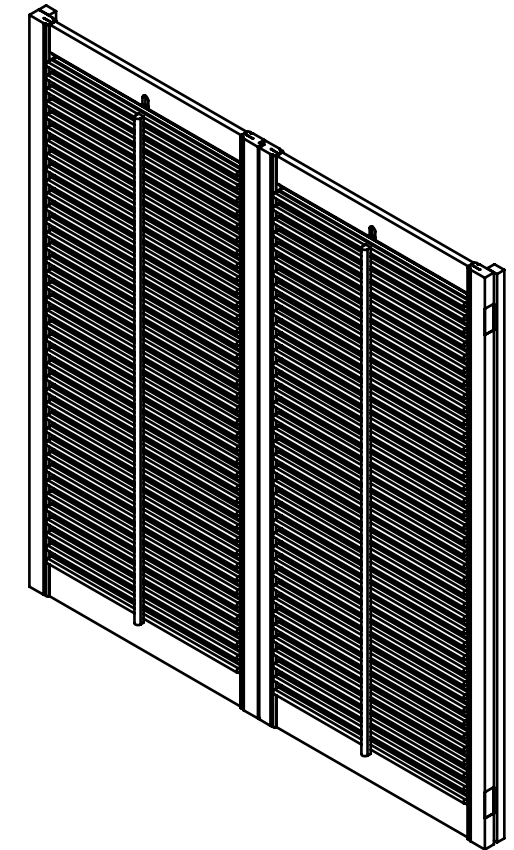

Approval Signature

Date

The signature (or AAN Stamp) on this print indicates the approval of the design, dimensions, and quantities shown. Authorization for this product to be manufactured is given.

**\*\*\*ALL PARTS SHOWN ARE ADAMS STANDARD PROFILES\*\*\***

**\*\*\*TWO DIMENSION REVISIONS ARE INCLUDED\*\*\***

**\*\*\*ANY CHANGES TO PROFILES/PARTS WILL INCUR ADDITIONAL CHARGES\*\*\***

UNLESS OTHERWISE SPECIFIED  
DIMENSIONS ARE IN INCHES

TOLERANCES:



2225 Kerper Blvd.  
Dubuque, IA 52001  
563-690-1358 p  
563-557-8852 f

**Traditional Louvered Shutter  
2 Leaf Set**

SHEET 1 OF 3

SIZE  
B

REV  
A

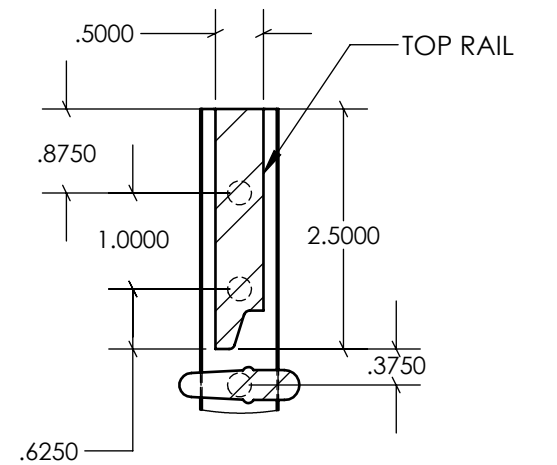
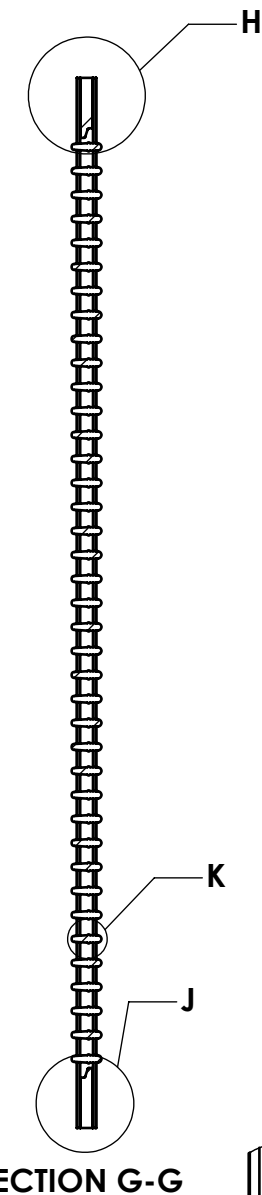
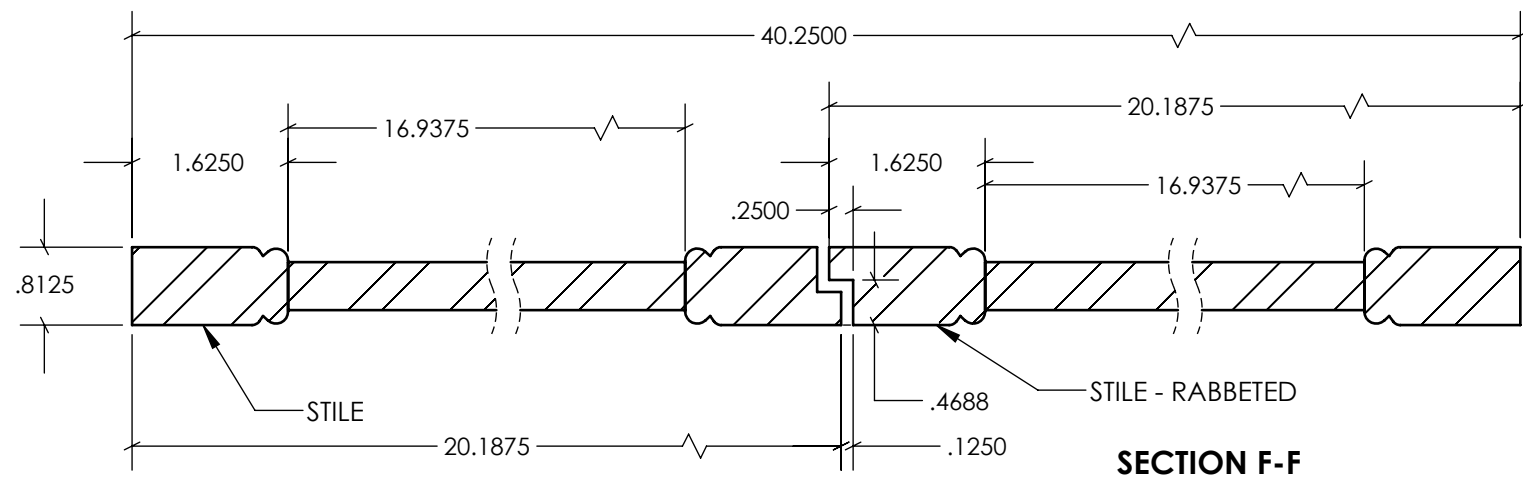
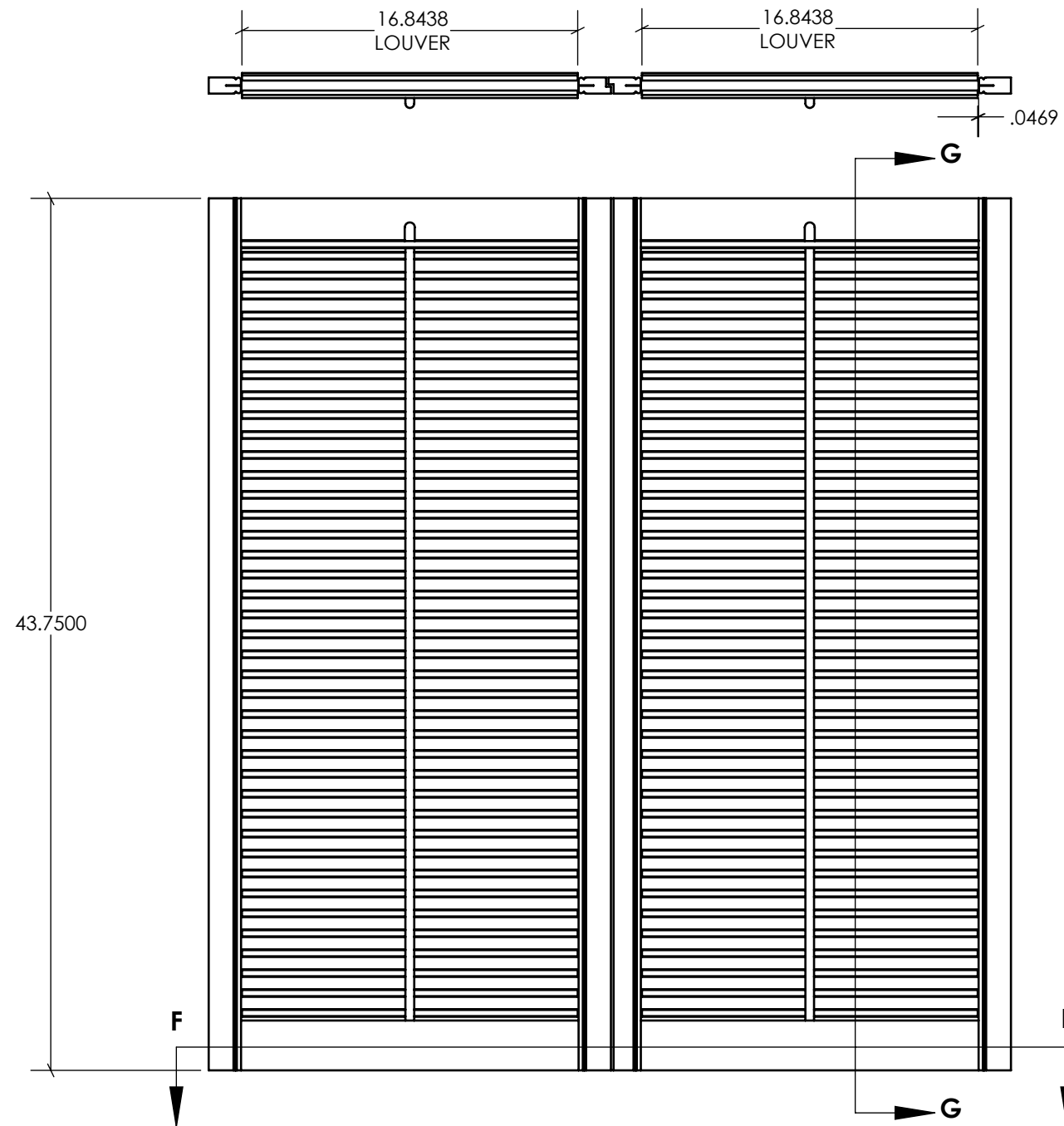

DETAIL H

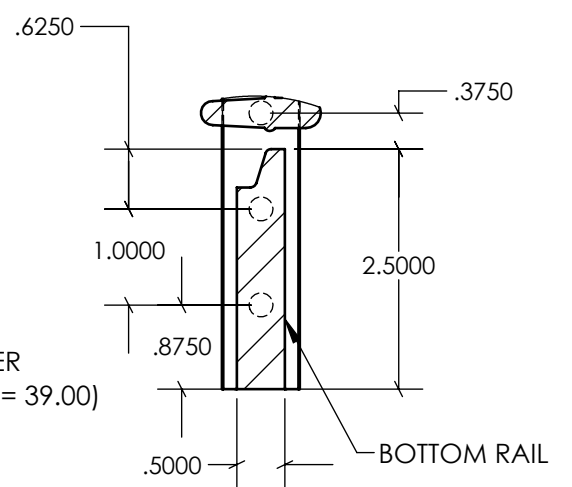

DETAIL J

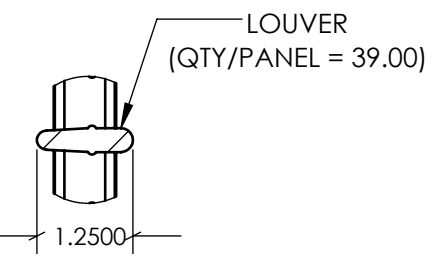

UNLESS OTHERWISE SPECIFIED DIMENSIONS ARE IN INCHES		2225 Kerper Blvd. Dubuque, IA 52001 563-690-1358 p 563-557-8852 f	
		<b>Traditional Louvered Shutter 2 Leaf Set</b>	
TOLERANCES:			
SHEET 2 OF 3	SIZE B		REV A

**HINGE LOCATIONS  
(HANGING STOPS HIDDEN)**

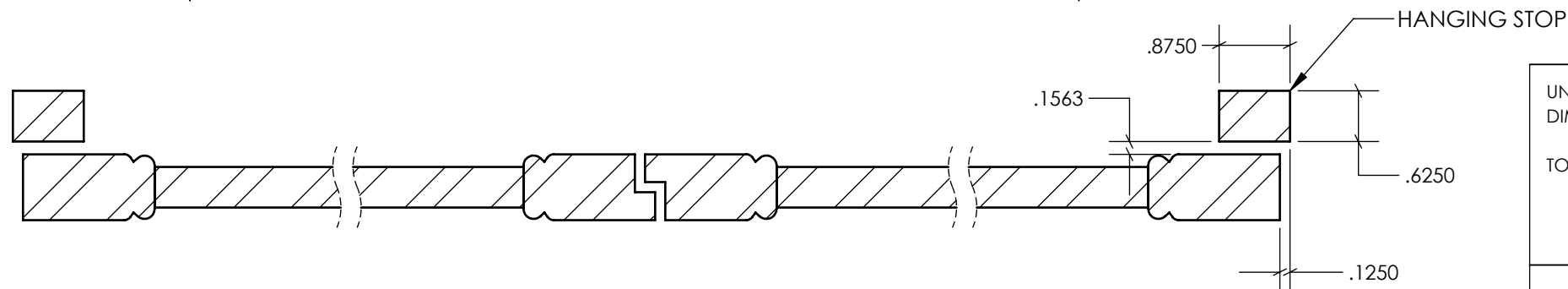
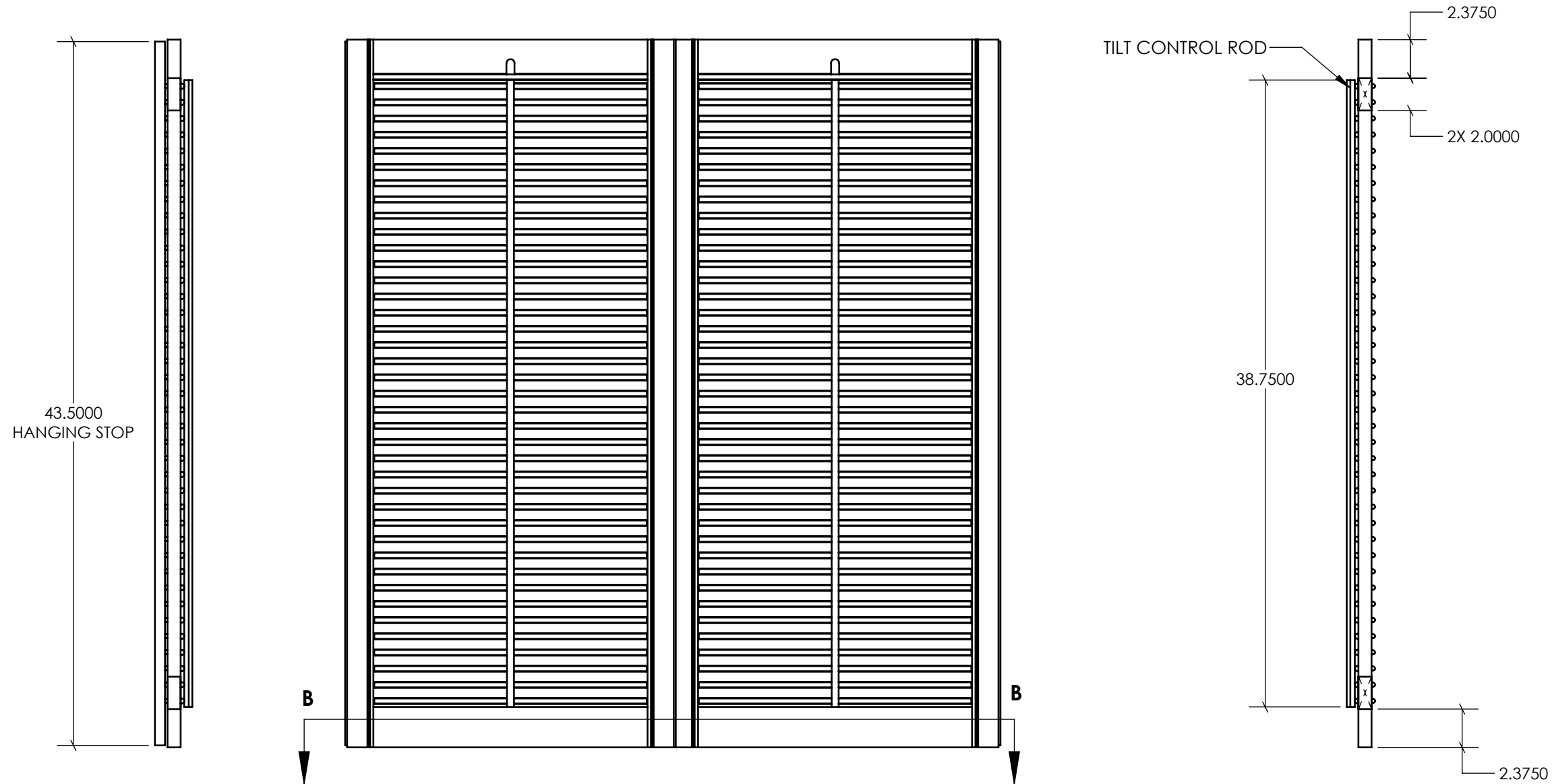

**SECTION B-B**

UNLESS OTHERWISE SPECIFIED DIMENSIONS ARE IN INCHES		2225 Kerper Blvd. Dubuque, IA 52001 563-690-1358 p 563-557-8852 f	
		<b>Traditional Louvered Shutter 2 Leaf Set</b>	
TOLERANCES:			
SHEET 3 OF 3	SIZE B		REV A